



OPERATING
INSTRUCTIONS



ReSound V
Model V70

ReSound V



GN RESOUND V SERIES BEHIND-THE-EAR PERSONAL HEARING SYSTEM

Congratulations on the purchase of your new fully-digital GN ReSound hearing instrument!

GN ReSound's state-of-the-art technology and the customized set-up selected by your hearing care professional will bring outstanding sound quality to your family, social and professional life.



Your hearing instrument has been adjusted to your individual hearing loss. Please familiarize yourself with the information in this booklet. Proper understanding and use of your new GN ReSound hearing instrument will allow you to derive maximum hearing benefit.



ReSound V is a trademark of ReSound A/S.

Contents

Page

Your ReSound V Hearing Instrument	4-5
User Operated Controls	6
Volume Control	6
Programme Selector	6
Your ReSound V set-up	7
Stand-by Function	7
On/Off Function	7
Changing the Battery	8
Battery Warning Information	9
Daily Maintenance	10
The Ear mould	11-12
Sound Outlet Filter	13
Telephone Use	14
Using Assistive Listening Systems	15
Repairs	15
Troubleshooting Guide	16-17
General Precautions	18
Technical Data	18
Key Word Index	19

Your ReSound V Hearing Instrument

1. Mode Selector
2. Battery Compartment
3. Sound Outlet
4. Microphone Sound Inlet

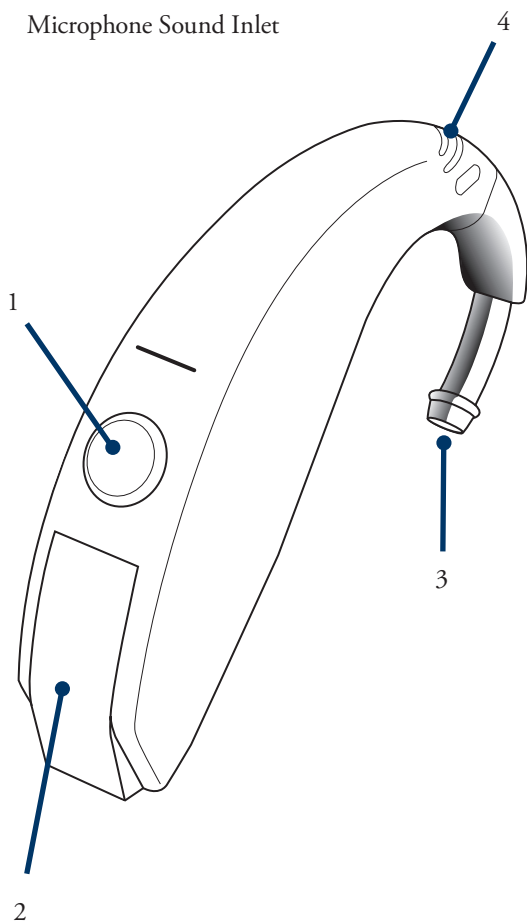

5. Model

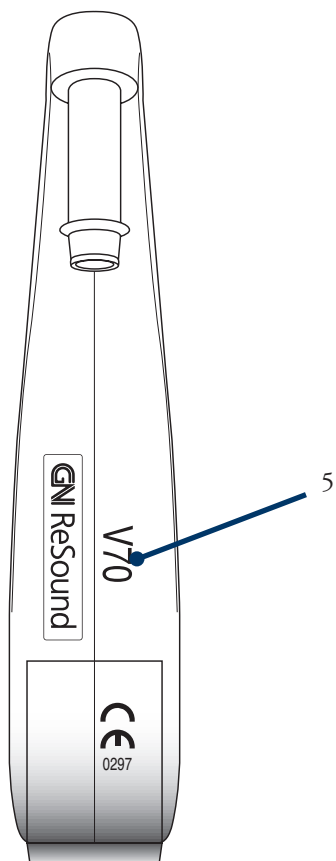

User Operated Controls

Volume Control

The volume control in your ReSound V instrument is fully automatic, so there is no need to bother with adjustments. Your instrument has been programmed to vary its amplification according to your needs. However you have the option of decreasing the volume by selecting the Comfort Mode, a standard feature for more comfort in noisy environments with less demanding speech understanding needs (in the car, in the mall).

Mode Selector

In ReSound V you have a basic programme and 3 different modes. The first mode is the Comfort Mode, and if you select the telecoil option you have additionally the T and MT modes. If your hearing care professional has programmed the telecoil option with the specific modes into your instrument, you can select the modes simply by depressing the push button. You will then hear one or more “beeps”, indicating which mode you have selected. Your hearing instrument will switch modes as follows:

Example with 3 modes:

Basic programme → Comfort Mode,
Comfort Mode → MT mode,
MT mode → T mode,
T mode → Basic programme

Example with 2 modes:

Basic programme → Comfort Mode,
Comfort Mode → T or MT mode,
T or MT mode → Basic programme

Example with 1 modes:

Basic programme → Comfort Mode,
Comfort Mode → Basic programme

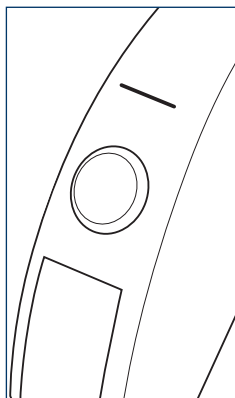

You can always return to the basic programme by turning your instrument off and then on again (see “On/Off Function”) or by placing it in stand-by mode and then returning to its normal function mode (see “Stand-by Function” on the next page).

Your ReSound V set-up

Basic	
Comfort Mode	
Telecoil ()	Microphone/Telecoil ()
Telecoil ()	

Stand-by Function

To put the instrument into stand-by mode, hold down the mode selector for 5 seconds. You will hear a series of beeps, and the device is now in stand-by mode. Before returning to functional mode, you will need to wait approximately 5 seconds. After waiting, press the mode selector down once. Please note that the instrument is using a small amount of power when in stand-by mode.

On/Off Function

Your ReSound V BTE (Behind-The-Ear) is equipped with an on/off switch integrated into the battery compartment. When the battery compartment is fully closed, the instrument is turned on in its functional mode and the basic programme will be activated. To turn the instrument off, press the tab on the base of the instrument with your fingertip. The battery compartment then snaps partly open and the instrument is turned off. Whenever you are not wearing the instrument, remember to turn it off to reduce battery consumption.



Changing the Battery

When the battery voltage/power decreases to a certain level, the instrument will stop amplifying and emit a soft beeping signal. This signal will continue for about one minute and then the instrument will be automatically switched off. Therefore, it is recommended that you keep a spare battery on hand.

Open the battery compartment by turning the instrument off, and then using your fingernail to open it completely. After removing the old battery, insert the new one with the “+” (flat) side facing the “+” on the battery door. It should fit in like a puzzle piece. The battery door should close very easily. Never use force to close the door as this may damage your hearing instrument.

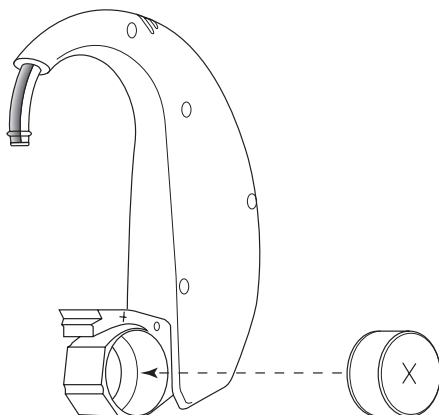
Always use a size 13 Zinc-Air battery. Please note that if the battery is weak, the hearing instrument performance will be reduced. Removing the battery when you are not wearing the instrument will help prevent corrosion of the battery contacts.







Battery Warning Information

Batteries contain dangerous substances and should be disposed of carefully in the interest of your safety and for the environment.

- Do NOT attempt to recharge batteries which are not specifically designated rechargeable as they may leak or explode.
- Do NOT attempt to dispose of batteries by burning them.
- Keep batteries away from small children and pets.
- Do NOT place batteries in your mouth.

If swallowed, see a physician immediately.



Daily Maintenance

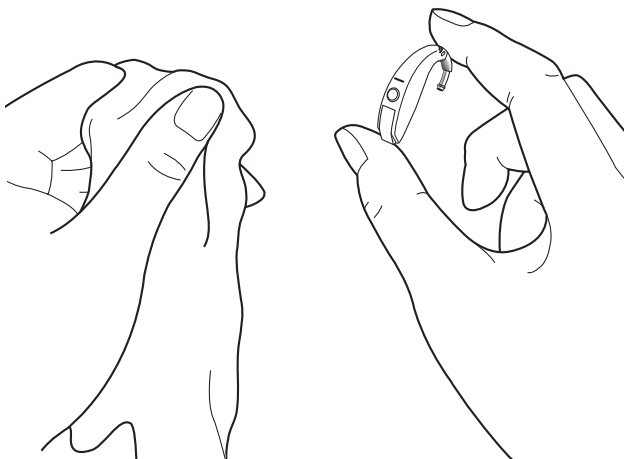

Keep your hearing instrument clean and dry. Wipe the case with a soft cloth or tissue after use to remove grease or moisture. If the instrument has been exposed to high humidity or perspiration, enclose it (with the ear mould) in a sealed container together with a drying agent (dessicator) overnight. Consult your hearing care professional as to which drying agent to use.

To avoid the need for unwarranted repairs:

- Never immerse the instrument in water or other liquids since this may cause permanent damage to the circuitry.
- Protect your hearing instrument from rough handling, and avoid dropping it on hard surfaces or floors.
- Do not leave the instrument in or near direct heat or sunlight since excessive heat can damage the instrument or deform the casing.

The Ear mould

The ear mould feeds the amplified sound from the hearing instrument into the ear. It is important the ear mould fits correctly into your ear. If the ear mould irritates your ear in any way and prevents you from wearing your hearing instrument, please contact your hearing care professional to have the ear mould modified. You should never attempt to modify the shape of the ear mould yourself.

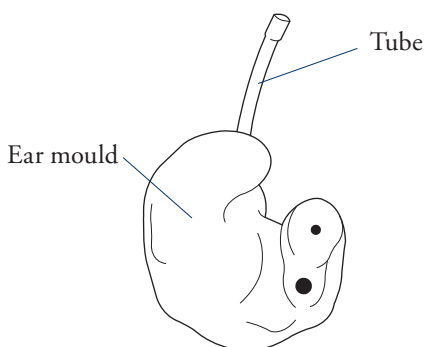

The ear mould should be cleaned regularly. Remove the ear mould and the silicone tubing from the hearing instrument before you clean it. Lukewarm water should be enough to clean wax off the ear mould. If ear wax is stuck in the sound canal of the ear mould, the cleaning loop or a syringe with lukewarm water can easily be used to “push” the wax out. Be sure to thoroughly dry the ear mould and its tubing before reconnecting it to the hearing instrument. Blow gently through the tubing to remove moisture trapped inside.

The silicone tubing connecting the ear mould to the hearing instrument should be changed if it becomes stiff or brittle.

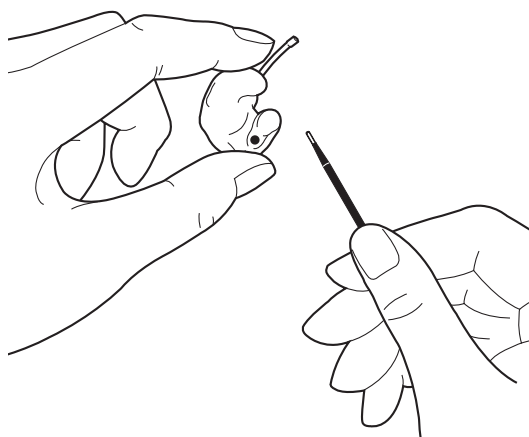

Sound Outlet Filter

Your ReSound V hearing instrument is equipped with a filter. This filter is located at the top of the sound outlet and prevents moisture and debris from getting into the hearing instrument. If the hearing instrument seems to have lost power and changing the battery does not help, the filter may be blocked, and needs to be changed.

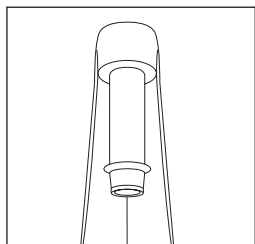

See instructions below:

How to remove filter

Place the hook of the instrument into the long groove of the filter stick. Pull down and the filter will be removed.

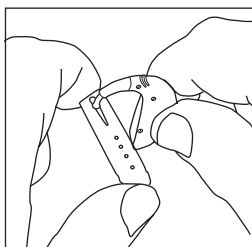

How to place filter on hook

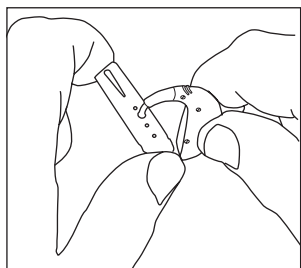

Place the hook on one filter and push gently. Rock the hook back and forth until the filter is released.

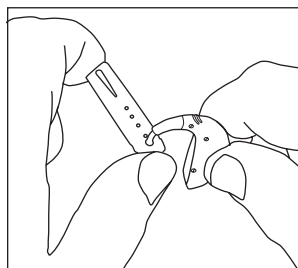

Now take the hook with the filter attached and press it in the hole at the end of the filter. The filter will now be fastened.

Telephone Use

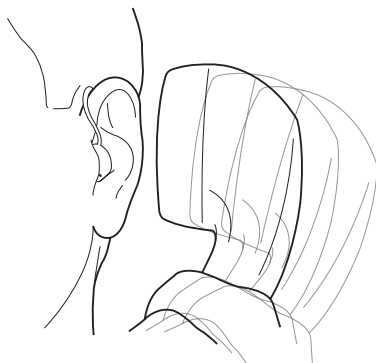

Your hearing instrument is equipped with an induction coil (telecoil) which picks up magnetic emanations from a hearing instrument compatible telephone. Your hearing care professional can set up your ReSound V hearing instrument to take advantage of the telecoil. By selecting the telecoil programme, the hearing instrument will only pick up the sounds coming from the telephone.

When using the telecoil programme, the receiver of the telephone should be held as shown in the drawing. You may need to move the handset around slightly to find the best reception.



Not all telephones are compatible with the induction coil in the hearing instrument, which will therefore not function in the telecoil programme. In that case stay in the basic programme.

Using the telephone, while wearing your hearing instrument may require some practice.



Using Assistive Listening (Tele-loop) Systems

Many gathering places are equipped with assistive listening (Tele-loop) systems, e.g. in schools, theaters and houses of worship. To take advantage of a Tele-loop system, select the telecoil mode. When the telecoil mode has been selected, you will be able to hear a clean sound signal via the Tele-loop system. If the instrument goes dead in the telecoil mode, this may be because the loop system is not operating. If a school, theater or house of worship does not have a Tele-loop system, try and sit as close as possible to the front. If you prefer to be able to hear your family sitting next to you, you can select the MT mode (microphone/telecoil) instead of just having the telecoil mode activated.



Repairs



If your GN ReSound hearing instrument malfunctions, it must be repaired by a qualified technician. Do not attempt to open the case of the hearing instrument since this would invalidate the warranty. If your GN ReSound hearing instrument requires service, please contact your hearing care professional for assistance.

TROUBLESHOOTING GUIDE

SYMPTOM	CAUSE
Dead	<ul style="list-style-type: none">• Not turned on• Dead battery• Battery improperly inserted• Blocked ear mould• Blocked sound outlet filter
Not loud enough	<ul style="list-style-type: none">• Loose ear mould• Blocked ear mould• Change in hearing• Excessive ear wax• Blocked sound outlet filter • Volume set too low
Whistles	<ul style="list-style-type: none">• Loose ear mould• Volume set too high
Not clear, Distorted	<ul style="list-style-type: none">• Weak battery• Poorly fitting ear mould• Hearing instrument damaged• Hearing instrument settings not optimum

If there are any other problems not mentioned in this guide, please contact your hearing care professional.



POSSIBLE REMEDY

- Turn on
- Replace battery
- Insert battery properly
- Clean ear mould blockage
- Change filter or consult your hearing care professional



- Reinsert carefully
- Clean ear mould
- Consult your hearing care professional
- Consult your physician
- Change filter or consult your hearing care professional
- Consult your hearing care professional

- Remove and reinsert
- Consult your hearing care professional

- Replace battery
- Consult your hearing care professional
- Consult your hearing care professional
- Consult your hearing care professional



General Precautions

- Consult a physician if you find a foreign object in your ear canal, if you experience skin irritation or if excessive ear wax accumulates with the use of the hearing instrument.
 - Different types of radiation, e.g. from NMR or CT scanners, may damage the hearing instrument. Therefore, do not wear the hearing instrument during these or other corresponding scanning procedures. Other types of radiation (burglary alarms, room surveillance systems, radio equipment, mobile telephones, etc) contain less energy and will not damage the hearing instrument. They could however momentarily affect the sound quality or create strange sounds from the hearing instruments.
 - **Warning:** Do not wear the hearing instrument in mines or other explosive areas, unless those areas are certified for hearing instrument use.
- 
- 

Technical Data

Maximum output
(2cc coupler / IEC 60118-7) 123 dB SPL (Typical)

Key Word Index

Assistive listening (Tele-loop) systems	15
Battery change	8
Battery compartment	4,8
ReSound V set-up	7
Cerumen/earwax	12
Cleaning the instrument	10,12
Ear mould	11,12
Low battery warnings	8
Maintenance	10,12
On/off switch	4,7
Sound Outlet filter	13
Stand-by mode	7
Telecoil use	14,15
Telephone use	14
Troubleshooting guide	16-17
User operated controls	4,6,7
Volume control	6



Please ask your local hearing care professional concerning disposal of your hearing instrument



ReSound



rediscover hearing

Worldwide headquarters

ReSound A/S
Lautrupbjerg 7
DK-2750 Ballerup, Denmark
Tel.: +45 45 75 11 11
Fax: +45 45 75 11 19
www.resound.com

United Kingdom

GN ReSound Ltd.
Kirtlington Business Centre
Portway
Kirtlington
Oxon OX5 3JA
Tel.: +44 1869 352 800
Fax: +44 1869 343 466
www.gnresound.co.uk

Australia

GN ReSound Pty. Ltd.
Unit R1 Regents Park Estate
391 Park Road
Regents Park NSW 2143
Tel.: (free) 1800 658 955
Fax: +61 2 9743 7472
www.gnresound.com.au

New Zealand

GN ReSound (NZ) Ltd.
12 Parkway Drive
Mairangi Bay
Auckland
Tel.: (free) 0800 900 126
Fax: (free) 0800 007 695
www.gnresound.co.nz

Any issues relating to the EU Medical Device Directive 93/42/EEC should be directed to ReSound A/S.



15674700-GB-10.09 Rev. B

ReSound V