

ReSound

OPERATING INSTRUCTIONS



ReSound V
Model
V50 - V40

ReSound V

GN RESOUND V SERIES IN-THE-EAR PERSONAL HEARING SYSTEM MODEL V50/V40

Congratulations on the purchase of your new fully-digital GN ReSound hearing instrument!

GN ReSound's state-of-the-art technology and the customized set-up selected by your hearing care professional will bring outstanding sound quality to your family, social and professional life.

Your hearing instrument has been adjusted to your individual hearing loss. Please familiarize yourself with the information in this booklet. Proper understanding and use of your new GN ReSound hearing instrument will allow you to derive maximum hearing benefit.

ReSound V is a trademark of GN ReSound.

Contents

page

| | |
|--|-------|
| Your ReSound V Hearing Instrument | 4-5 |
| User Operated Controls | 6 |
| Mode Selector | 6 |
| Your ReSound V set-up | 7 |
| Stand-by Function | 7 |
| On/Off Function | 7 |
| Insertion of the Hearing Instrument | 8 |
| Removal of the Hearing Instrument | 9 |
| Changing the Battery | 9 |
| Battery Warning Information | 10 |
| Daily Maintenance | 11 |
| Cleaning the Microphone Sound Inlet | 12 |
| Changing the Sound Outlet Filter/ Cleaning the Sound Outlet | 12 |
| Telephone Use | 13 |
| Using Assistive Listening Systems | 14 |
| Repairs | 14 |
| Troubleshooting Guide | 16-17 |
| General Precautions | 18 |
| Technical Data | 18 |
| Key Word Index | 19 |

Your ReSound V Hearing Instrument

1. Mode Selector
2. Battery Compartment
3. Microphone Sound Inlet
4. Air Vent

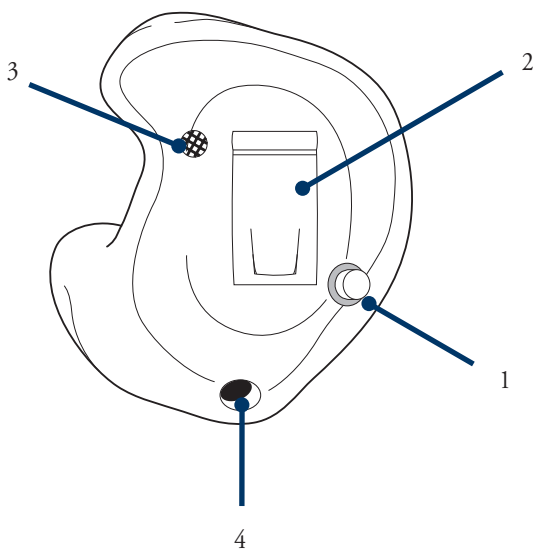

6. Sound Outlet
7. Model
8. Year of Manufacture
9. Serial Number
10. Manufacturer

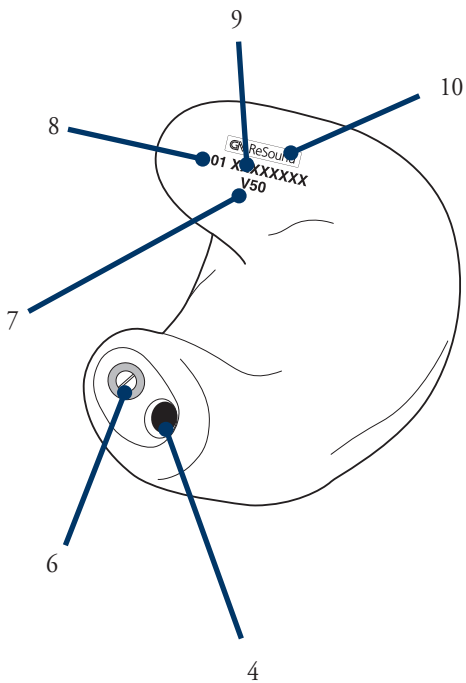

User Operated Controls

Mode Selector

In ReSound V you have a basic programme and 3 different modes. The first mode is the Comfort Mode, and if you select the telecoil option you have additionally the T and MT modes. If your hearing care professional has programmed the telecoil option with the specific modes into your instrument, you can select the modes simply by depressing the push button. You will then hear one or more “beeps”, indicating which mode you have selected. Your hearing instrument will switch modes as follows:

Example with 3 modes:

Basic programme → Comfort Mode,
Comfort Mode → MT mode,
MT mode → T mode,
T mode → Basic programme

Example with 2 modes:

Basic programme → Comfort Mode,
Comfort Mode → T or MT mode,
T or MT mode → Basic programme

Example with 1 mode:

Basic programme → Comfort Mode,
Comfort Mode → Basic programme

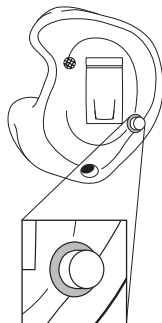

You can always return to the basic programme by turning your instrument off and then on again (see “On/Off Function”) or by placing it in stand-by programme and then returning to its normal function programme (see “Stand-by Function” on the next page).

Your ReSound V set-up

| | |
|--------------|-------------------------|
| Basic | |
| Comfort Mode | |
| Telecoil () | Microphone/Telecoil () |
| Telecoil () | |

Stand-by Function

To put the instrument into stand-by mode, hold down the mode selector for 5 seconds. You will hear a series of beeps, and the device is now in stand-by mode. Before returning to functional mode, you will need to wait approximately 5 seconds. After waiting, press the mode selector once. Please note that the instrument is using a small amount of power when in stand-by mode.

On/Off Function

Your ReSound V ITE (In-The-Ear) is equipped with an on/off switch integrated into the battery compartment. When the battery compartment is fully closed, the instrument is turned on in its functional mode and the basic programme will be activated. To turn the instrument off, open the battery compartment with your fingernail. Whenever you are not wearing the instrument, remember to turn it off to reduce battery consumption.

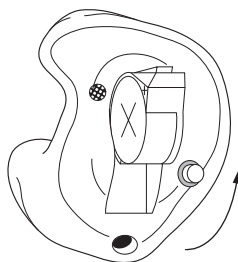

Insertion of the Hearing Instrument

To insert the hearing instrument into your ear:

1. Grip the instrument with your thumb and forefinger, either above and below or on the sides (as shown) with the programme selector on top.
2. Place the sound outlet portion into your ear canal.
3. Insert the hearing instrument carefully with a slight “corkscrew” motion.

By experimenting, you may find a method that is easier for you. When properly inserted, the instrument should fit comfortably and tightly in your ear. It is important that the custom shell fits correctly into your ear. If your hearing instrument irritates your ear in any way and prevents you from wearing your hearing instrument, please contact your hearing care professional to have the custom shell modified. You should never attempt to modify the shape of the custom shell yourself.

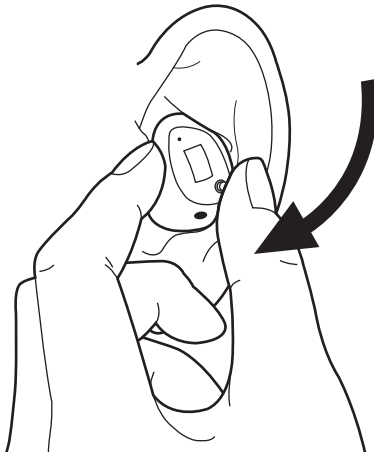

Removal of the Hearing Instrument

To remove the hearing instrument:

1. Run your finger along the top of the instrument to displace the top portion from the outside of your ear.
2. Place your thumb on the bottom and forefinger on the top of the instrument, and carefully remove the instrument out of your ear canal with a slight “corkscrew” motion.

By experimenting, you may find a method that is easier for you. Consult your hearing care professional if you have difficulty removing the hearing instrument.

Changing the Battery

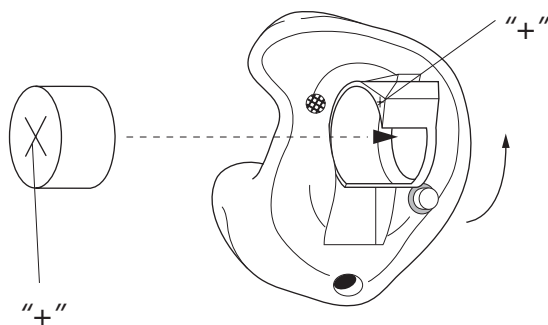

When the battery voltage/power decreases to a certain level, the instrument will stop amplifying and emit a soft beeping signal. This signal will continue for about one minute and then the instrument will be automatically switched off. Therefore, it is recommended that you keep a spare battery on hand.

Open the battery compartment completely using your fingernail, as described earlier. After removing the old battery, insert the new one with the “+” (flat) side facing the “+” on the battery door. It should fit in like a puzzle piece. The battery door should close very easily. Never use force to close the door as this may damage your hearing instrument.

Always use a size 13 Zinc-Air battery (V50) or a size 312 (V40). Please note that if the battery is weak, the hearing instrument performance will be reduced. Removing the battery when you are not wearing the instrument will help prevent corrosion of the battery contacts and reduce battery consumption.

Battery Warning Information

Batteries contain dangerous substances and should be disposed of carefully in the interest of your safety and for the environment.

- Do NOT attempt to recharge batteries which are not specifically designated rechargeable as they may leak or explode.
- Do NOT attempt to dispose of batteries by burning them.
- Keep batteries away from small children and pets.
- Do NOT place batteries in your mouth.

If swallowed, see a physician immediately.

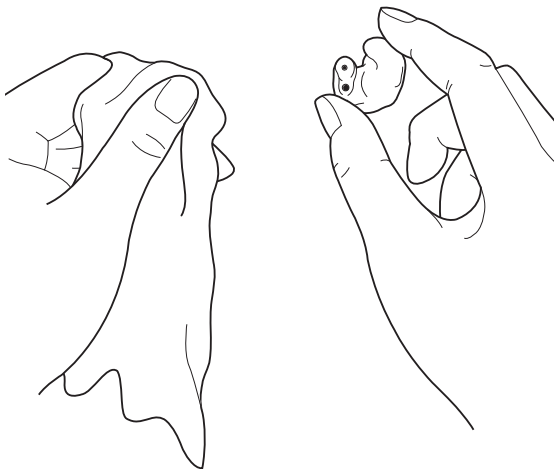

Daily Maintenance

Keep your hearing instrument clean and dry. Wipe the case with a soft cloth or tissue after use to remove grease or moisture. If the instrument has been exposed to high humidity or perspiration, enclose it in a sealed container together with a drying agent (dessorbent) overnight. Consult your hearing care professional concerning which drying agent to use.

To avoid the need for unwarranted repairs:

- Never immerse the instrument in water or other liquids since this may cause permanent damage to the circuitry.
- Protect your hearing instrument from rough handling, and avoid dropping it on hard surfaces or floors.
- Do not leave the instrument in or near direct heat or sunlight since excessive heat can damage the instrument or deform the casing.

Cleaning the Microphone Sound Inlet

For proper function of the microphones, it is important to clean the sound inlets to remove dust or other sound disturbing debris. The soft brush, provided with your hearing instrument, can be used for this purpose. Your hearing care professional can instruct you on how to properly use this tool.

Changing the Sound Outlet Filter/ Cleaning the Sound Outlet

Your ReSound V hearing instrument may be equipped with a sound outlet filter (consult your hearing care professional). This filter is located at the end of the sound outlet and prevents debris from getting into the hearing instrument. If the hearing instrument seems to have lost power and changing the battery does not help, the filter may be blocked, and needs to be changed. Your hearing care professional can instruct you on how to change the filter.

If your hearing instrument does not have a filter, ear wax and/or other debris may collect in the sound channel. The cleaning loop, provided with your hearing instrument, can easily be used to remove this material. Your hearing care professional can instruct you on how to properly use this tool.

When using this tool, be careful not to damage or pull the tubing found at the opening of the sound outlet. If this is pulled out, the hearing instrument may need to be returned for repair.

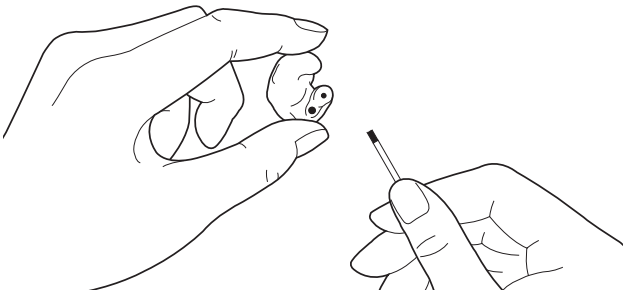

Telephone Use

Your hearing instrument may be equipped with an induction coil (telecoil) which picks up magnetic emanations from a hearing instrument compatible telephone. Your hearing care professional can set up your ReSound V hearing instrument to take advantage of the telecoil. By selecting the telecoil programme, the hearing instrument will only pick up the sounds coming from the telephone.

When using the telecoil programme, the receiver of the telephone should be held as shown in the drawing. You may need to move the handset around slightly to find the best reception.

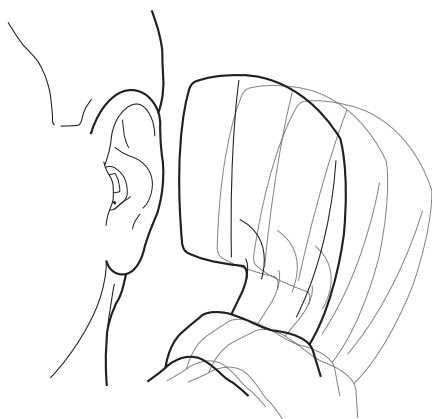

Not all telephones are compatible with the induction coil in the hearing instrument, which will therefore not function in the telecoil programme. In that case stay in the basic programme.

Using the telephone while wearing your hearing instrument may require some practice.

Using Assistive Listening (Tele-loop) Systems

Many gathering places are equipped with assistive listening (Tele-loop) systems, e.g. in schools, theaters and houses of worship. To take advantage of a Tele-loop system, select the telecoil mode. When the telecoil mode has been selected, you will be able to hear a clean sound signal via the Tele-loop system. If the instrument goes dead in the telecoil mode, this may be because the loop system is not operating. If a school, theater or house of worship does not have a Tele-loop system, try and sit as close as possible to the front.

If you prefer to be able to hear your family sitting next to you, you can select the MT mode (microphone/telecoil) instead of just having the telecoil mode activated.

Repairs

If your GN ReSound hearing instrument malfunctions, it must be repaired by a qualified technician. Do not attempt to open the case of the hearing instrument since this would invalidate the warranty. If your GN ReSound hearing instrument requires service, please contact your hearing care professional for assistance.

TROUBLESHOOTING GUIDE

| SYMPTOM | CAUSE |
|-----------------------------|---|
| Dead | <ul style="list-style-type: none">• Not turned on• Battery low/dead• Battery improperly inserted• Blocked sound outlet• Blocked cerumen filter |
| Not loud enough | <ul style="list-style-type: none">• Battery low• Instrument loose• Blocked sound outlet• Blocked cerumen filter• Change in hearing• Excessive ear wax• Volume set too low |
| Whistles | <ul style="list-style-type: none">• Instrument improperly inserted• Poorly fitting instrument |
| Not clear, Distorted | <ul style="list-style-type: none">• Battery low• Poorly fitting instrument |

POSSIBLE REMEDY

- Turn on
- Replace battery
- Insert battery properly
- Clean sound outlet
- Change cerumen filter

- Replace battery
- Reinsert carefully
- Clean sound outlet
- Change cerumen filter
- Consult your hearing care professional
- Consult your physician
- Consult your hearing care professional

- Remove and reinsert
- Consult your hearing care professional

- Replace battery
- Consult your hearing care professional

General Precautions

- Consult a physician if you find a foreign object in your ear canal, if you experience skin irritation or if excessive ear wax accumulates with the use of the hearing instrument.
- Different types of radiation, e.g. from NMR or CT scanners, may damage the hearing instrument. Therefore, do not wear the hearing instrument during these or other corresponding scanning procedures. Other types of radiation (burglary alarms, room surveillance systems, radio equipment, mobile telephones, etc) contain less energy and will not damage the hearing instrument. They could however momentarily affect the sound quality or create strange sounds from the hearing instruments.
- Warning: Do not wear the hearing instrument in mines or other explosive areas, unless those areas are certified for hearing instrument use.

Technical Data

Maximum output
(2cc coupler / IEC 60118-7) 118 dB SPL (Typical)

Key Word Index

| | |
|---|--------|
| Assistive listening (Tele-loop) systems | 14 |
| Battery change | 9-10 |
| Battery compartment | 4,9-10 |
| ReSound V set-up | 7 |
| Cerumen/earwax | 12 |
| Cleaning the instrument | 11,12 |
| Insertion | 8 |
| Low battery warnings | 9 |
| Maintenance | 11,12 |
| Mode selector | 4,6 |
| On/off function | 7 |
| Removal | 9 |
| Sound outlet | 4,12 |
| Stand-by mode | 7 |
| Telecoil use | 13,14 |
| Telephone use | 13 |
| Troubleshooting guide | 16-17 |
| User operated controls | 4,6 |



Please ask your local hearing care professional concerning disposal of your hearing instrument

Any issues relating to the EU Medical Device Directive 93/42/EEC should be directed to GN ReSound A/S.



Faceplate/Electronics by:
GN ReSound A/S

Worldwide headquarters:

GN ReSound A/S
Lautrupbjerg 7
DK-2750 Ballerup, Denmark
Tel.: +45 45 75 11 11
Fax: +45 45 75 11 19
www.resound.com

United Kingdom

GN ReSound Ltd.
Kirtlington Business Centre
Portway
Kirtlington
Oxon OX5 3JA
Tel.: +44 1869 352 800
Fax: +44 1869 343 466
www.gnresound.co.uk

Australia

GN ReSound Pty. Ltd.
Unit R1 Regents Park Estate
391 Park Road
Regents Park NSW 2143
Tel.: (free) 1800 658 955
Fax: +61 2 9743 7472
www.gnresound.com.au

New Zealand

GN ReSound (NZ) Ltd.
12 Parkway Drive
Mairangi Bay
Auckland
Tel.: (free) 0800 900 126
Fax: (free) 0800 007 695
www.gnresound.co.nz